

Clamps for fatigue tests with vertical forces

ISO 4210-6 parte: 4.5

EN 15194 parte: 4.3.7.6

Clamping kit for running fatigue tests on the bicycle frame with vertical forces applied on the saddle support post or directly on the saddle. Compatible with the BYC-100 series frame.

Includes three complete accessories:

- Bracket with coupling for saddle post
- Central carriage with linear rails
- Rear support with cylindrical coupling

Bracket with coupling for saddle post

The bracket allows the saddle post, assembled on the frame, to be connected with the actuator which will apply the test force.

Complete with double ball coupling to eliminate the lateral loads on the actuator rod.

Compatible with the interface plate of the BYC-100 frame. Available in different sizes that can be made according to customer specifications.

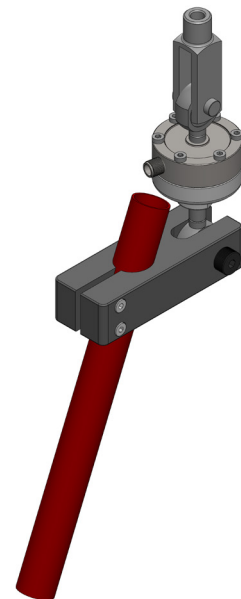
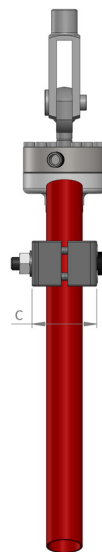
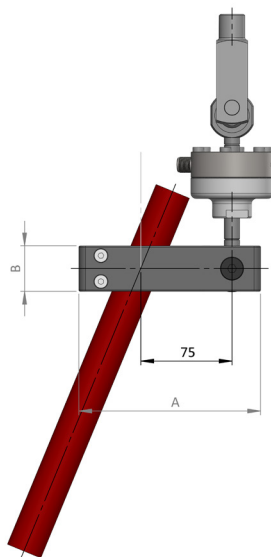

Rif.	Dimensions [mm]
A	140
B	35
C	60

Central carriage with linear rails

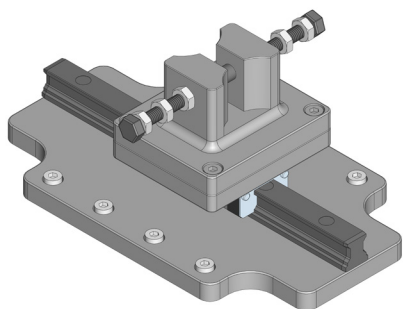

Allows the frame fork to be secured to the carriage positioned on the linear rail. The actuator rod which will generate the horizontal cyclical movement is connected to the carriage by means of the pin and the ball coupling.

Compatible with the interface plate of the BYC-100 frame.

Rif.	Dimensions [mm]
A	180
B	300
C	130
H	96

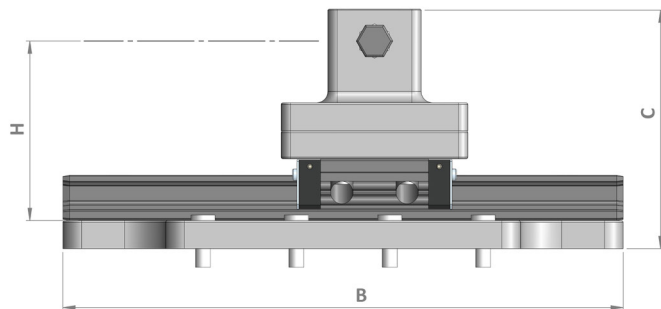
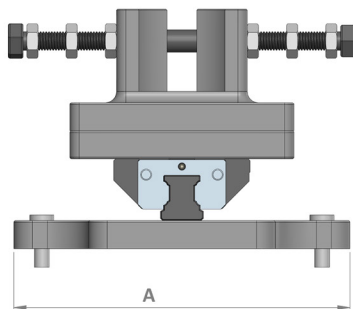

Rear support with cylindrical coupling

Allows the rear fork of the bicycle to be secured to the frame. As specified in the standard, the support is fitted with a bottom cylindrical coupling.

It is compatible with the interface plate of the BYC-100 frame and height-adjustable.

Available in different sizes that can be made according to customer specifications.

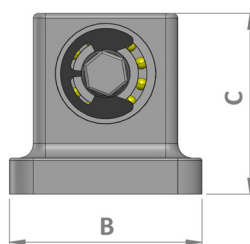
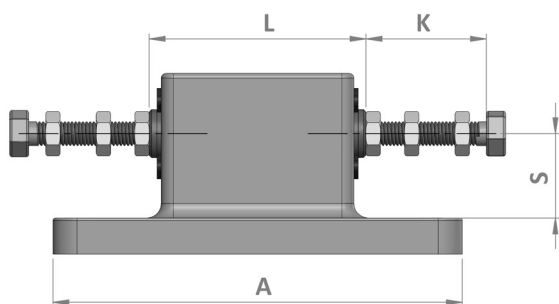
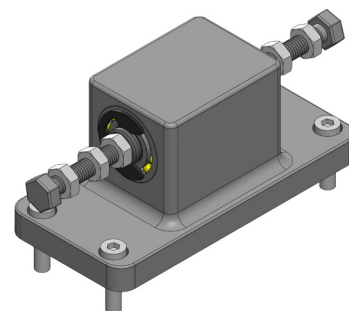

Rif.	Dimensions [mm]
A	170
B	80
C	75
L	90
K	45
S	35

Al fine di migliorare le prestazioni tecniche del prodotto, la società si riserva di apportare variazioni senza preavviso.
In order to improve the technical performances of the product, the company reserves the right to make any change without notice.

DRC Srl
PRODUCTION and SALES

Via Montesicuro, 58/B - 60131 Ancona (Italy)
Tel (+39) 071 80 36 077

GENERAL INFORMATION
info@litem.info

www.litem.info